

1 METAL PIPE THROUGH CONCRETE FLOOR (2-HR.)
M.1.1 NOT TO SCALE

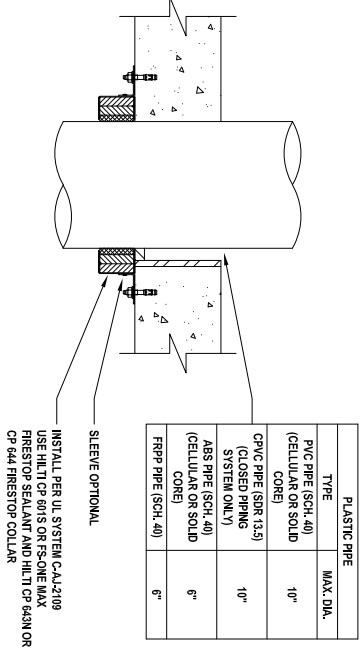

3 PLASTIC PIPE THROUGH CONCRETE FLOOR (2-HR.)
M.1.1 NOT TO SCALE

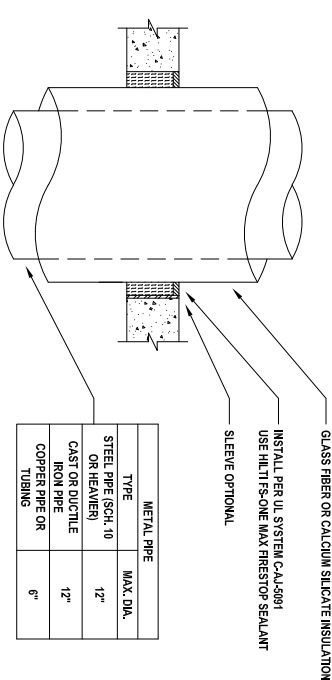

6 METAL PIPE WITH GLASS FIBER OR CALCIUM SILICATE INSULATION THROUGH CONCRETE FLOOR (2-HR.)
M.1.1 NOT TO SCALE

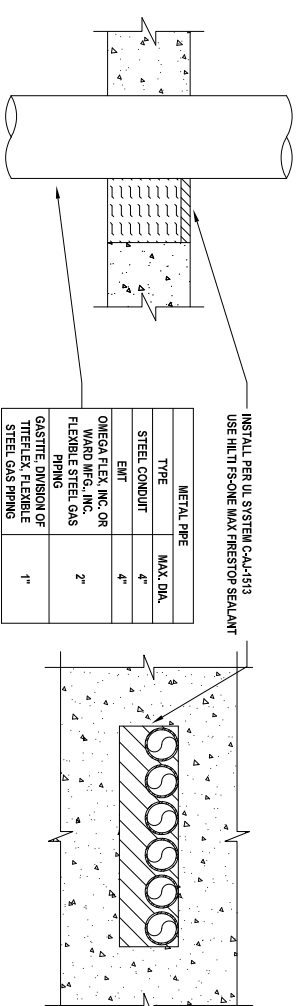

2 MULTIPLE METAL PIPES THROUGH CONCRETE FLOOR (2-HR.)
M.1.1 NOT TO SCALE

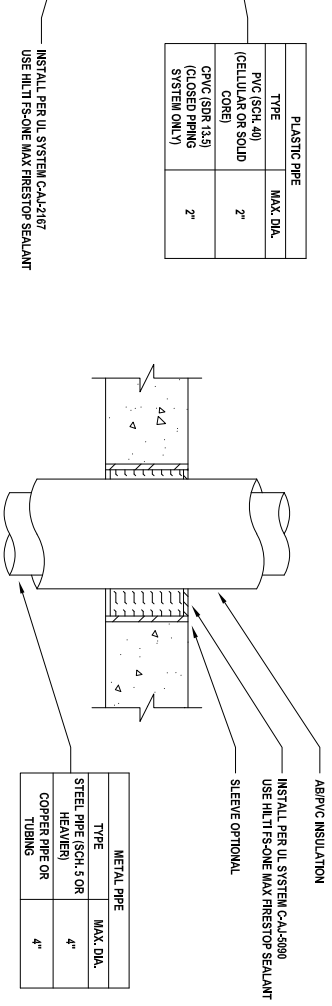

4 PLASTIC PIPE THROUGH CONCRETE FLOOR (2-HR.)
M.1.1 NOT TO SCALE

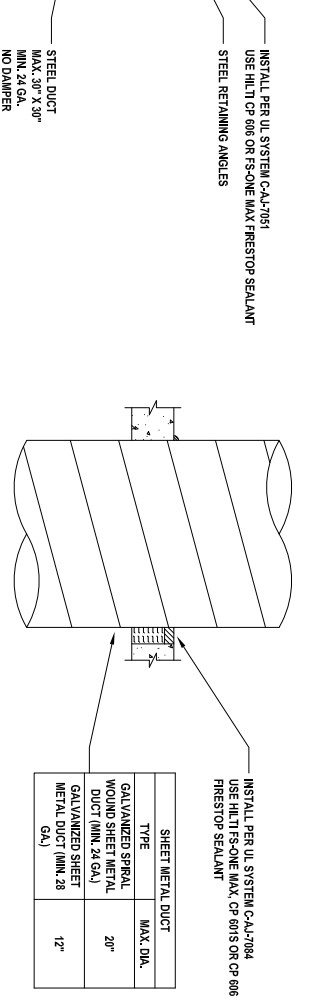

5 METAL PIPE WITH AB/PVC INSULATION THROUGH CONCRETE FLOOR (2-HR.)
M.1.1 NOT TO SCALE

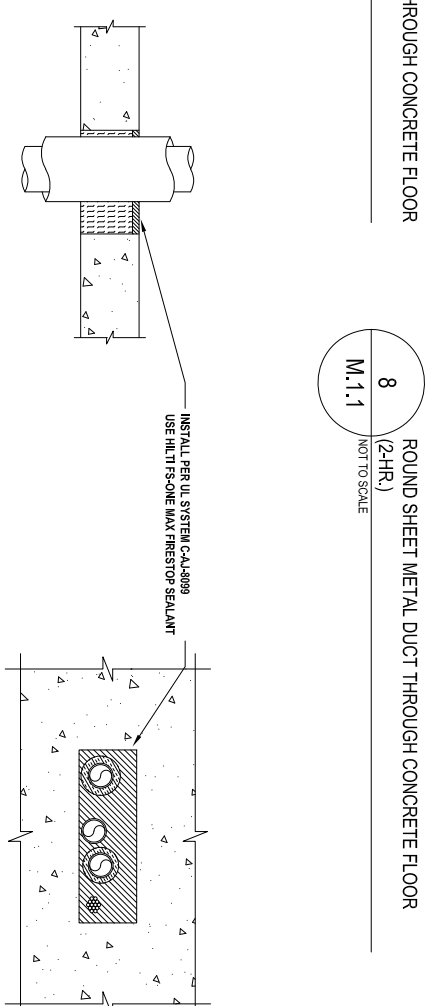

7 METAL DUCT (WITHOUT DAMPER) THROUGH CONCRETE FLOOR (2-HR.)
M.1.1 NOT TO SCALE

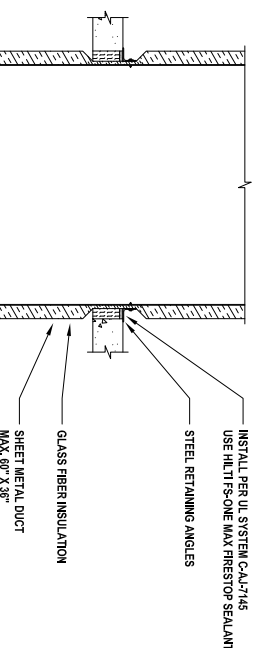

9 SHEET METAL DUCT WITH GLASS FIBER INSULATION THROUGH CONCRETE FLOOR (2-HR.)
M.1.1 NOT TO SCALE

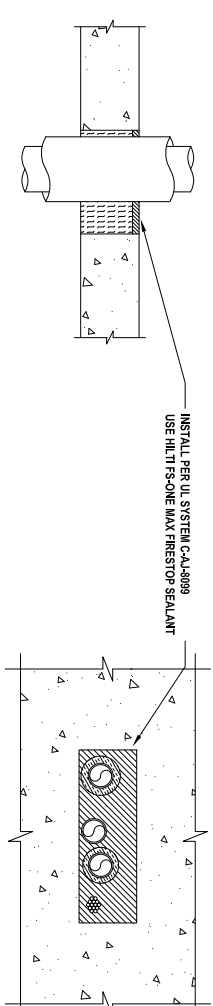

8 ROUND SHEET METAL DUCT THROUGH CONCRETE FLOOR (2-HR.)
M.1.1 NOT TO SCALE

10 MULTIPLE PENETRATIONS THROUGH CONCRETE FLOOR (2-HR.)
M.1.1 NOT TO SCALE

- Notes:
- Refer to the following specifications for firestopping.
 - Firestopping
 - Penetration Firestopping
 - Plumbing
 - HVAC
 - Electrical
 - Communication

For Quality Control requirements, refer to the Quality Control portion of the specification.
 2. Details shown are typical details, containing general information only. Always refer to the full UL system detail for complete system requirements. If field conditions do not match requirements of details, approved alternate details shall be utilized. Design requirements, field conditions and dimensions need to be verified for compliance with the details, including but not limited to the following:

- * Fire Rating (F-Rating)
- * Temperature Rating (T-Rating)
- * Leakage Rating (L-Rating)
- * Water Rating (W-Rating)
- * Annular Space
- * Percent Fill
- * Movement

3. If alternate details matching the field conditions are not available, manufacturer's engineering judgment drawings are acceptable. Contact Hilti for alternative systems or Engineering Judgment. Drawings shall follow the International Firestop Council (IFC) Guidelines for Evaluating Firestop Systems Engineering Judgments.

4. References:
- * 2013 Underwriter's Laboratories Fire Resistance Directory, Volumes 1 & 2
 - * NFPA 101 Life Safety Code
 - * NFPA 70 - National Electric Code
 - * All governing local and regional building codes
5. Firestop System installation must meet requirements of ASTM E-814 (UL 1479) tested assemblies that provide a fire rating equal to that of construction being penetrated.

<Notes to designer (delete this note after reading and replace with title block information)>

- Any modification to these details could result in an application/system not meeting the UL or Intertek Classification or the intended temperature or fire ratings.
- Details shown are up to date as of 2021.
- For additional information on the details, refer to the most current "Underwriter's Laboratories Fire Resistance Directory (volume 2.)"

JOB NUMBER: _____

DRAWN: _____

CHECKED: _____

ISSUE DATE: _____

REVISIONS: _____

CONTENTS: _____

MECHANICAL PENETRATIONS
FLAT CONCRETE FLOOR
2 HR.

SHEET NAME: **M.1.1**

SHEET NUMBER: _____

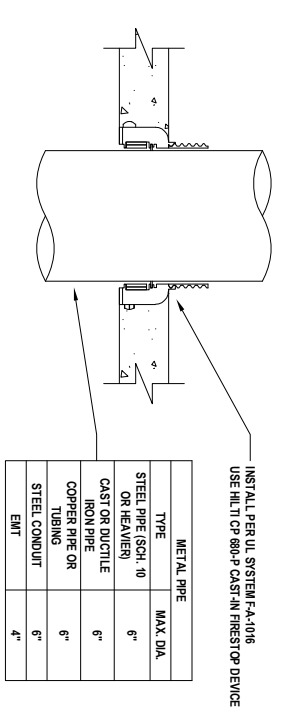

1 METAL PIPE THROUGH CONCRETE FLOOR (2-HR.)
M.1.2 NOT TO SCALE

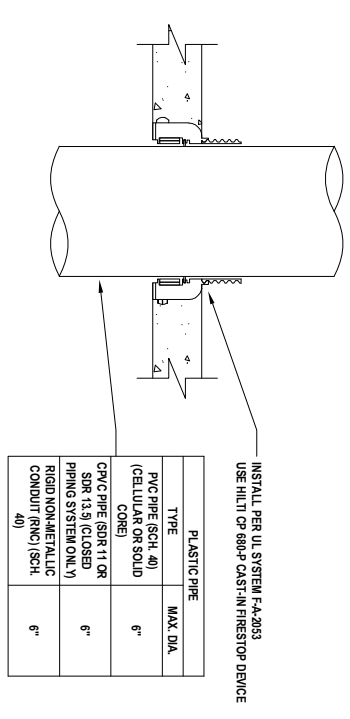

2 PLASTIC PIPE THROUGH CONCRETE FLOOR (2-HR.)
M.1.2 NOT TO SCALE

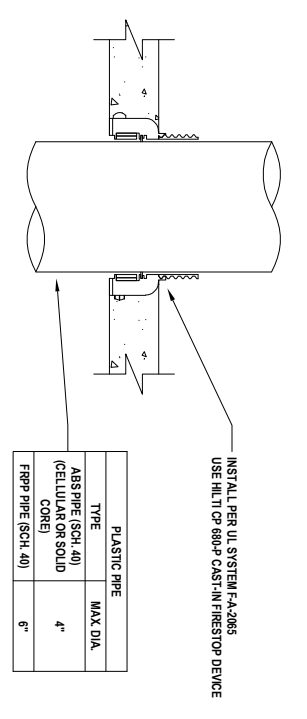

3 PLASTIC PIPE THROUGH CONCRETE FLOOR (2-HR.)
M.1.2 NOT TO SCALE

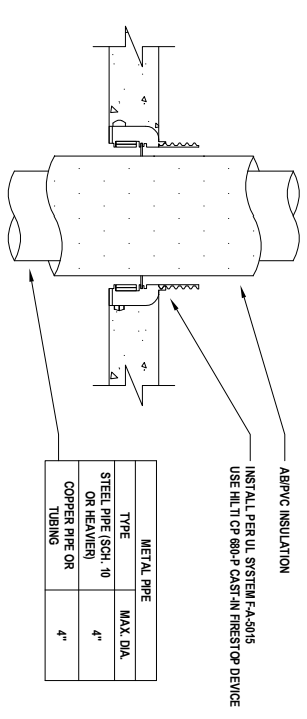

4 METAL PIPE WITH AB/PVC INSULATION THROUGH CONCRETE FLOOR (2-HR.)
M.1.2 NOT TO SCALE

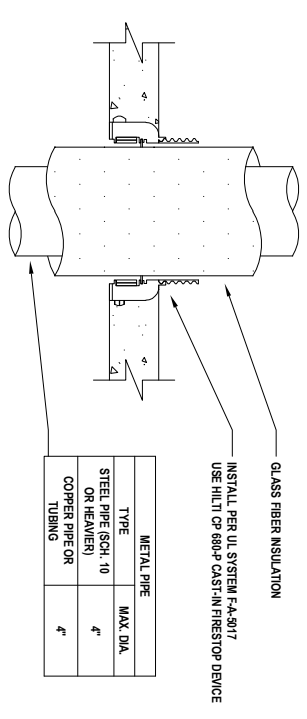

5 METAL PIPE WITH GLASS FIBER INSULATION THROUGH CONCRETE FLOOR (2-HR.)
M.1.2 NOT TO SCALE

Notes:

- Refer to the following specifications for firestopping:
 - Firestopping
 - Penetration Firestopping
 - Plumbing
 - HVAC
 - Electrical
 - Communication
- For Quality Control requirements, refer to the Quality Control portion of the specification.
- Details shown are typical details, containing general information only. Always refer to the full UL system detail for complete system requirements. If field conditions do not match requirements of details, approved alternate details shall be utilized. Design requirements, field conditions and dimensions need to be verified for compliance with the details, including but not limited to the following:
 - Fire Rating (F-Rating)
 - Temperature Rating (T-Rating)
 - Leakage Rating (L-Rating)
 - Water Rating (W-Rating)
 - Annular Space
 - Percent Fill
 - Movement
- Type and thickness of fire-rated construction.
- If alternate details matching the field conditions are not available, manufacturer's engineering judgment drawings are acceptable. Contact Hill for alternative systems or Engineering Judgment Drawings shall follow the International Firestop Council (IFC) Guidelines for Evaluating Firestop Systems Engineering Judgments.
- References:
 - 2013 Underwriter's Laboratories Fire Resistance Directory, Volumes 1 & 2
 - NFPA 101 Life Safety Code
 - NFPA 70 - National Electric Code
 - All governing local and regional building codes
- Firestop System installation must meet requirements of ASTM E-814 (UL 1479) tested assemblies that provide a fire rating equal to that of construction being penetrated.

<Notes to designer (delete this note after reading and replace with title block information)>

- Any modification to these details could result in an application/system not meeting the UL or Intertek Classification or the intended temperature or fire ratings.
- Details shown are up to date as of February 2021.
- For additional information on the details, refer to the most current "Underwriter's Laboratories Fire Resistance Directory (volume 2.)"

JOB NUMBER: _____

DRAWN: _____

CHECKED: _____

ISSUE DATE: _____

REVISIONS: _____

CONTENTS: _____

MECHANICAL PENETRATIONS
FLAT CONCRETE FLOOR
2 HR.

SHEET NAME: **M.1.2**

SHEET NUMBER: _____